

Earth Clean Tohoku Advanced Desiccant DES/DX10-40 (Commercial Dehumidifier)

~Benefits~

- Prevents mold for indoor
- Preserves drying and quality
- Prevents dew condensation
- Realize humidity control

① One-pass-desiccant that enable to get indoor air and supply the dried air, by a DX refrigeration loop with coupled with a desiccant dehumidification wheel.

② Achieve more than 5.0COP

An Ultra-efficient dehumidification Air Conditioner

③ Shorten ducting works and save installation works

DES/DX10

Processing air volume: 1,000m³/h type
Ceiling embedded



Desiccant Unit
(RA Circulating, Ceiling Embedded)

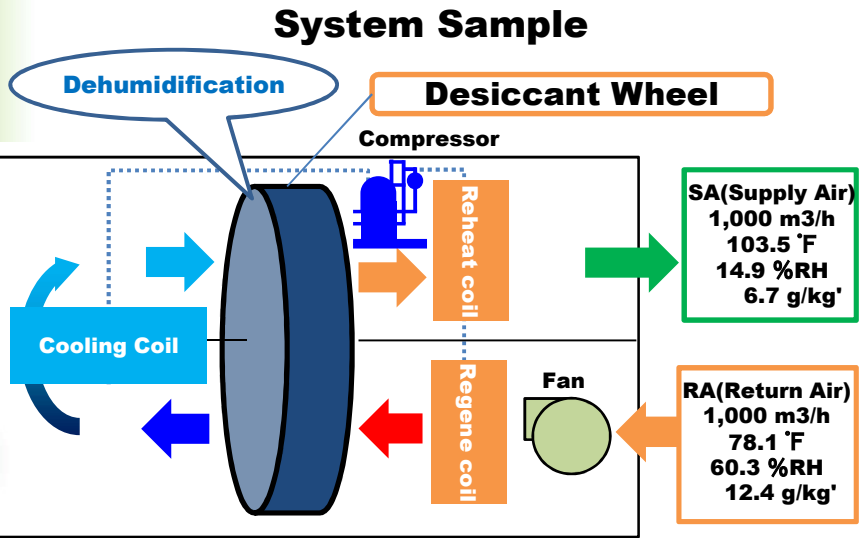

Dehumidification Volume ... 6.84kg/h
Dehumidification Capacity ... 4.8kW

DES/DX40

Processing air volume: 3,400m³/h type
Floor mounted



Desiccant Unit
(RA Circulating, Floor Mounted)

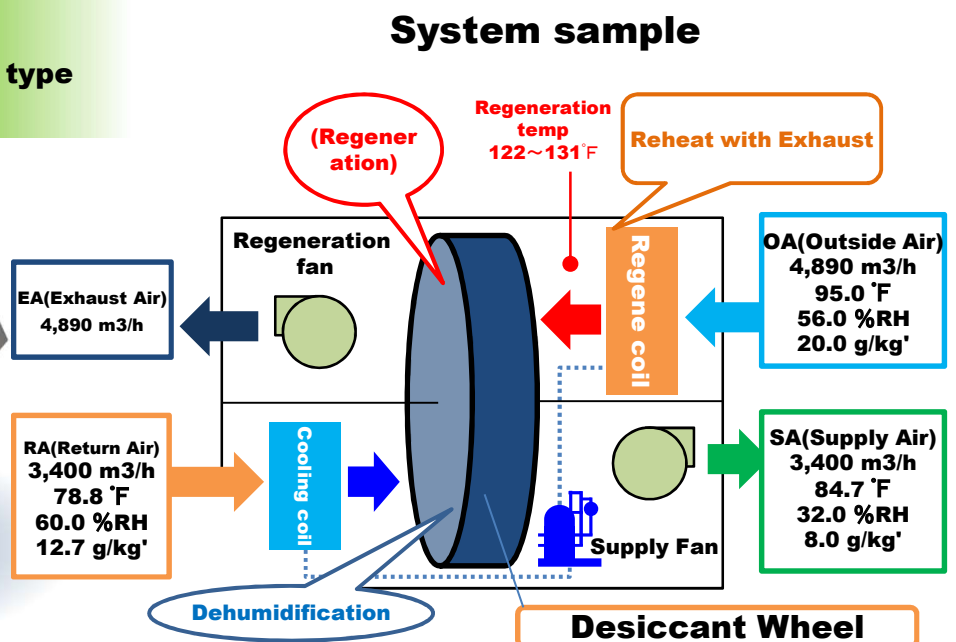

Dehumidification Volume ... 19.0kg/h
Dehumidification Capacity ... 13.3kW



Application Samples



Preserves warehouse and depot by eliminating condensation



Prevents dehumidification and dew condensation for super market, roof-space

Offering a Best space suitable to application

Unit Configuration

DES/DX10

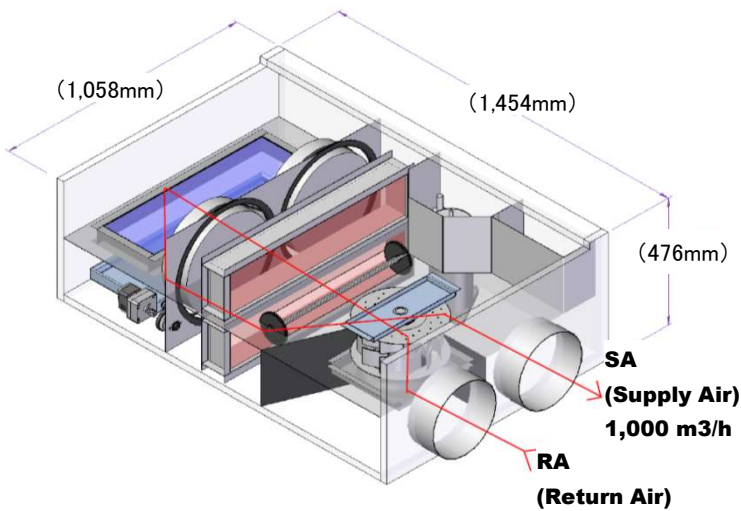

DES/DX40

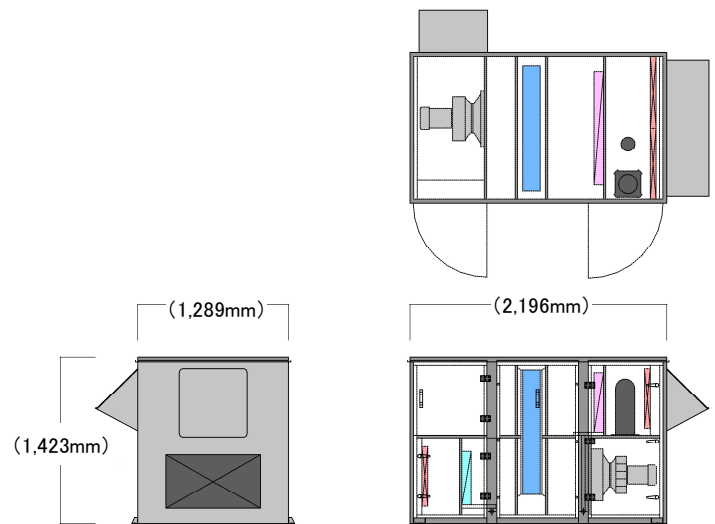

Unit Specification

Type	DES/DX10(Ceiling embedded)	DES/DX40(Floor mounted)
Processing air volume	1,000 m3/h	3,400 m3/h
Dimensions	L1,454 × W1,058 × H476(mm)	L2,196 × W1,289 × H1,423(mm)
Operating Weight	190kg	800kg
Power Source	Single 200V 50Hz/60Hz	3Phase 200V 50Hz / 60Hz
Power Consumption	2.62kW / 2.96kW	10.5kW
Dehumidification Capacity	4.8kW	13.3kW
Dehumidification Volume	6.84kg/h	19.0kg/h

This information contained in this brochure made out in August 1st, 2017 and is believed to be accurate by Earth Clean Tohoku, but is not warranted. Specifications subject to change without notice.



Earth Clean Tohoku CO., LTD

2-14-17, Izai, Wakabayashi-Ku, Sendai-City, Miyagi, Japan

TEL (+81) (0)22 (288) 2888 FAX (+81) (0)22 (288) 2890 HP <http://www.earthclean.co.jp>

(190509)